

INSTALLATION INSTRUCTIONS

SUBJECT: LML CP3 CONVERSION KIT FOR 2011-2016 DURAMAX

FPE-2021-56
January, 2022

FITMENT: 2011–2016 GMC Sierra and Chevrolet Silverado 2500/3500

P/N's: FPE-LML-CP3-WP, FPE-LML-CP3-NP, FPE-LML-CP3-10

EST. INST. TIME: 10 - 12 Hours

TOOLS REQUIRED: ½" fuel disconnect, 3/8" fuel disconnect, 3/8" ratchet, metric socket set, metric wrench set, 1 1/16" socket, 27mm socket, 3/8" socket extensions, fan clutch removal tool, 3/8" and ½" torque wrench, ¼" and 5/16" nut driver, pliers, 7/8" wrench, 15/16" wrench, pry bar, hose pick and Dorman 904-484 or CTA 3477 fuel line quick disconnect tool.

KIT CONTENTS:

Item	Description	Qty
1	CP3 injection pump (FPE-LML-CP3-WP and FPE-LML-CP3-10 kit only)	1
2	CP3 to engine block adapter	1
3	Fuel feed hose	1
4	Fuel return hose	1
5	High-pressure fuel line	3
6	Low pressure fuel feed line	1
7	CP3 feed fitting & sealing washer	1
8	CP3 return fitting & sealing washer	1
9	Hose clamps (2-#6, 3-#8)	5
10	Fuel rail nut and plug	1
11	O-rings (block adapter and pump)	2
12	M8x1.25x35mm bolts	3
13	Dosing injector feed line	1
14	Regulator extension harness	1
15	Fuel temp sensor mounting block	1
16	CARB EO Label (not pictured)	1



WARNINGS / IMPORTANT NOTES:

- Thoroughly clean all fuel lines and components prior to installation with a solvent solution.
- For optimal performance, if the truck is equipped with a lift pump, the feed pressure to the CP3 should not exceed 11 psi. Engine surging may be experienced at lift pump pressures over 11 psi.
- The purchaser and end user releases, indemnifies, discharges, and holds harmless Fleece Performance Engineering, Inc. from any and all claims, damages, causes of action, injuries, or expenses resulting from or relating to the use or installation of this product that is in violation of the terms and conditions on this page, the product disclaimer, and/or the product installation instructions. Fleece Performance Engineering, Inc. will not be liable for any direct, indirect, consequential,

INSTALLATION INSTRUCTIONS

GENERAL OVERVIEW

Removal of the stock fuel injection pump involves the following key steps:

1. Disconnect both batteries, drain coolant system and remove air cleaner.
2. Remove intake air box and coolant surge tank bracket.
3. Disconnect black plastic cold side charge air cooler tube from throttle body and blue hot side charge air cooler pipe from turbocharger.
4. Disconnect chassis fuel lines from quick connect fittings at rear of engine.
5. Release accessory drive belt tensioner and remove turbocharger air resonator.
6. Unbolt and move aside A/C compressor and alternator(s).
7. Unbolt cooling fan from front of engine, move aside.
8. Remove intake manifold tube.
9. Remove EGR bypass pipe, valve and front cooler.
10. Remove center intake manifold (Y bridge) and turbo air inlet adapter.
11. Remove turbocharger coolant return banjo pipe.
12. Remove high and low-pressure fuel lines.
13. Remove stock injection pump.
14. Swap gear and nut from the old CP4 injection pump to the new CP3 injection pump.

Installation of the new CP3 pump is as follows:

1. Install new injection pump (does not need to be timed).
2. Install secondary high-pressure rail plug.
3. Remove old high-pressure pump line anchor bracket from rail-to-rail high-pressure line.
4. Replace low pressure fuel supply tube with new tube and install to engine.
5. Install new supplied low pressure fuel supply hose and high-pressure fuel lines. Install new low pressure return hose and dosing injector feed line.
6. Install center intake manifold, EGR cooler, turbocharger air inlet adapter.
7. Install EGR bypass pipe, valve and intake manifold tube.
8. Reinstall turbocharger coolant banjo pipe w/ new seal.
9. Reinstall cooling fan assembly, alternator(s) and A/C compressor.
10. Install drive belt and turbocharger air resonator.
11. Reconnect cold side charge air cooler duct and hot side charge air cooler pipe.
12. Reconnect air cleaner, chassis fuel line connections, batteries.
13. Refill coolant.
14. Prime fuel system.

INSTALLATION INSTRUCTIONS

REMOVAL OF THE CP4 INJECTION PUMP

1. Disconnect both batteries, drain coolant system and remove air cleaner.
 - a. Do not use impact tools on the battery terminals.
 - b. Coolant is best drained from the lower radiator hose. Place a large bucket underneath the vehicle to drain the coolant into.
 - c. Air cleaner can be removed by first loosening the hose clamps and then gently pulling off the duct. The box itself can be removed by lifting upward. Be careful not to damage the A/C line during removal.
2. Remove airbox and coolant surge tank bracket. Next, disconnect black plastic cold side charge air cooler (CAC) tube from throttle body.
 - a. With a screwdriver, push the lock ring counterclockwise. As the locking ring is rotated, the CAC pipe itself can be gently pulled out and off.
 - b. Remove CAC pipe from the turbocharger.
3. Disconnect chassis fuel lines from quick connect fittings at rear of engine using a quick connect removal collar tool. Use 3/8" and 1/2" fuel disconnect tools to perform this.
4. Remove the four (4) cooling fan shroud bolts.
 - a. For 2015 vehicles, it is not necessary to remove the fan shroud, gently adjust the shroud towards the radiator to provide access to the cooling fan center.
 - b. For 2014 and earlier vehicles, the fan shroud is two piece and can be more easily removed.
 - c. Unbolt cooling fan mount from front of engine by loosening three 15mm bolts and two stud nuts.
 - d. Remove the fan from the drive pulley using a fan removal tool. Perform this before removing the belt.
5. Release tension of the accessory drive belt by rotating tensioner using a 1/2" drive socket wrench. The intake manifold cover (embossed with 6.6L Turbo Diesel) can be removed by loosening the two 10mm bolts affixing it to the intake pipe. Remove the alternator bracket.
6. Unbolt and move aside A/C compressor. The refrigerant does not need to be evacuated. The alternator(s) can be removed and put aside.

INSTALLATION INSTRUCTIONS

- a. Remove intake manifold tube. First loosen the two 13mm bolts affixing the pipe to the intake manifold near the MAP sensor. (see Fig. 1)
- b. Next, loosen the oil dipstick tube bracket bolts and the hidden 10mm bolt affixing the intake air heater ground bracket to the intake pipe. (see Fig. 1)

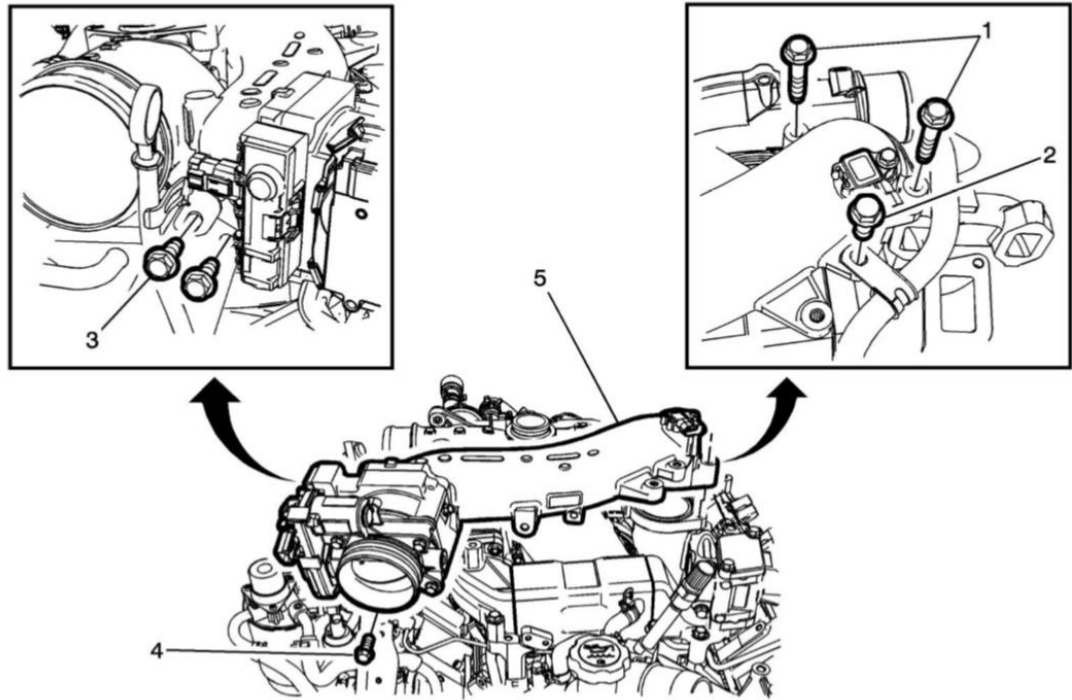

Fig. 1: Intake manifold tube

INSTALLATION INSTRUCTIONS

7. Remove the turbocharger air inlet adapter.

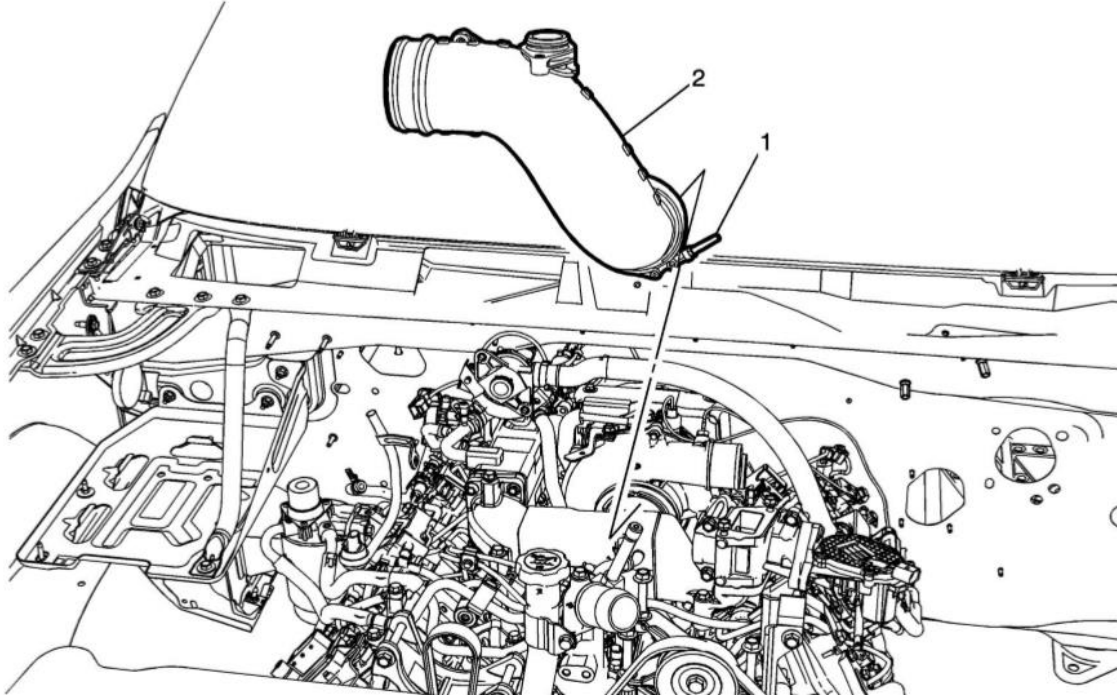

Fig. 2: Air inlet adapter removal

INSTALLATION INSTRUCTIONS

8. Remove EGR bypass pipe, valve and front cooler.
 - a. Remove the EGR bypass pipe that connects the EGR bypass valve to the EGR valve.

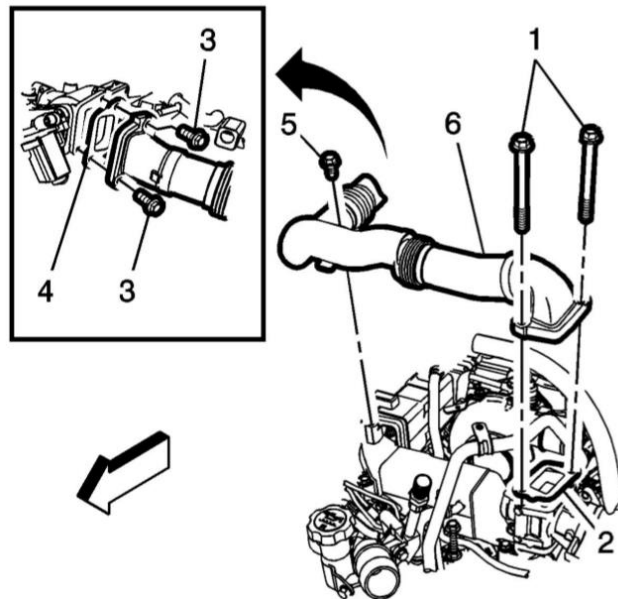

Fig. 3: EGR bypass pipe

- b. The EGR valve can then be removed by loosening the four bolts that attach it to the intake manifold.

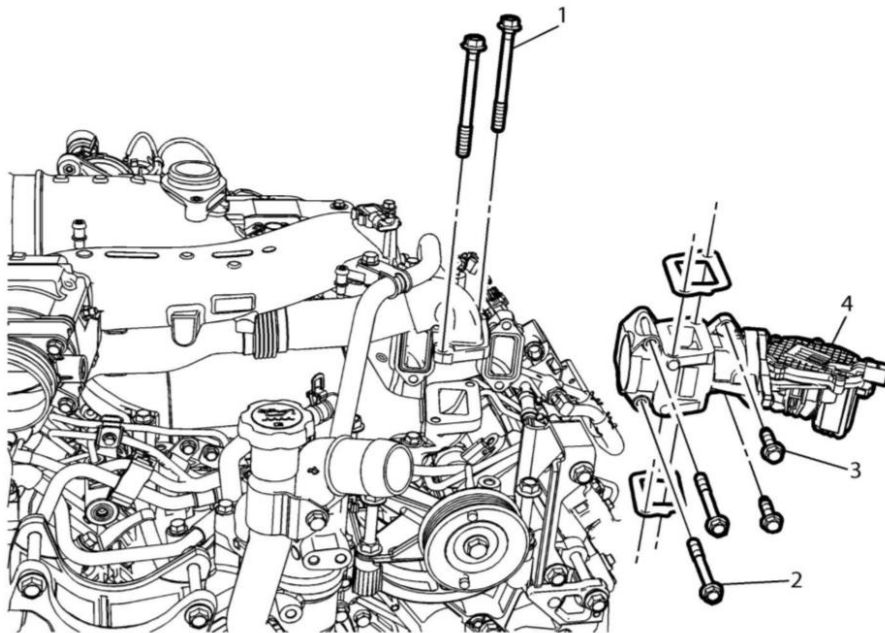

Fig. 4: EGR valve removal

INSTALLATION INSTRUCTIONS

- c. The 4 front EGR cooler bolts can be accessed by carefully threading through a ¼" drive socket extension and a swivel socket.

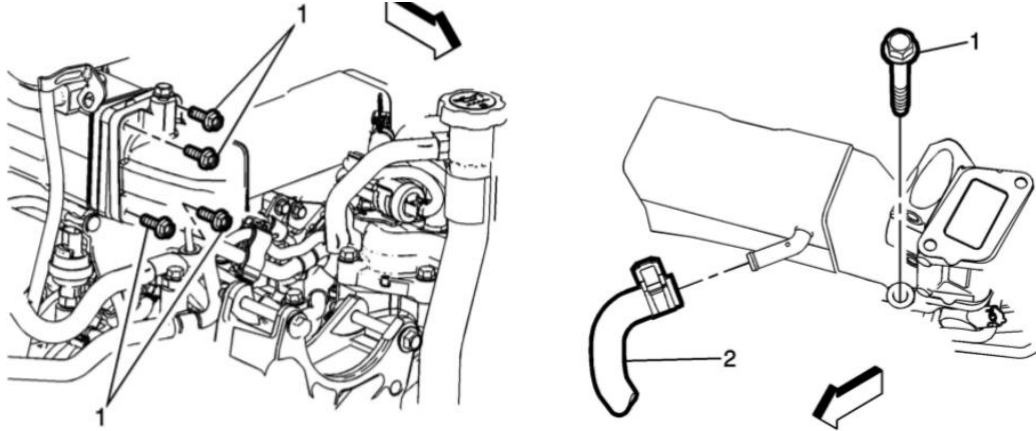

Fig. 5: EGR cooler removal

- 9. Remove the turbocharger air inlet adapter.

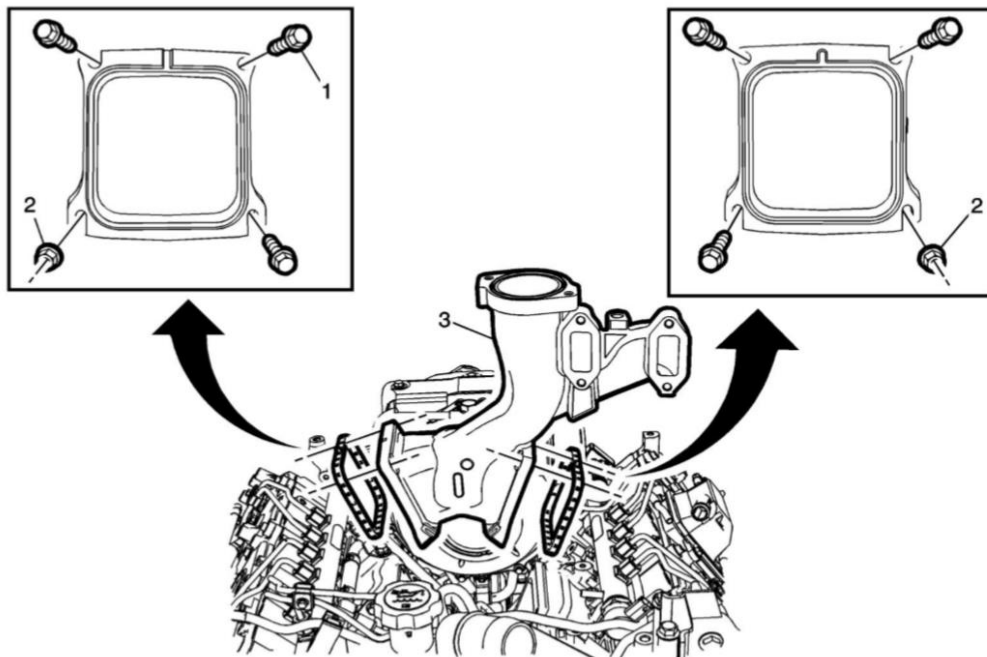

Fig. 6: Turbocharger air inlet removal

INSTALLATION INSTRUCTIONS

10. Remove turbocharger coolant return banjo pipe from the turbocharger (Item #5 in Fig. 7 below) -

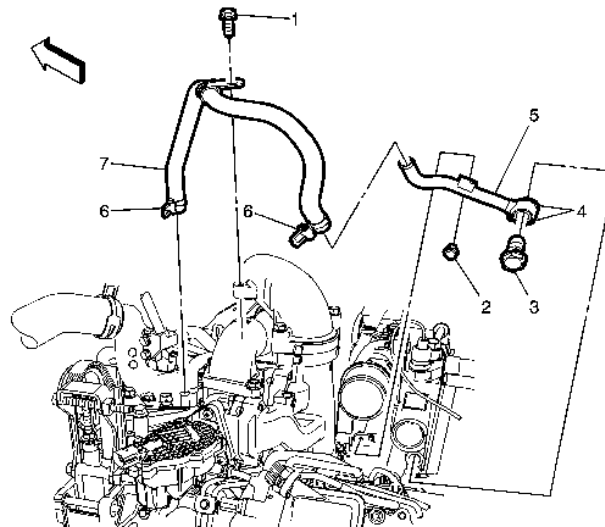

Fig. 7: Turbocharger coolant return pipe removal

11. Remove high- and low-pressure fuel lines.

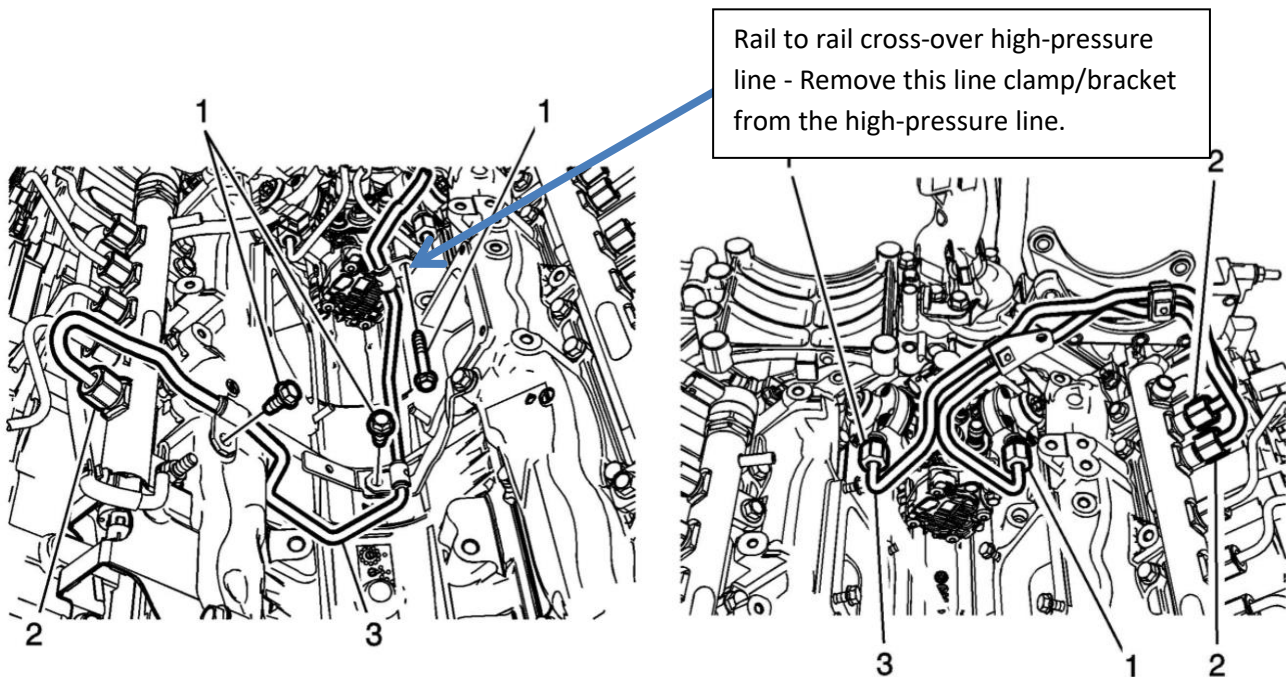

Fig. 8: High and low fuel pressure line removal

INSTALLATION INSTRUCTIONS

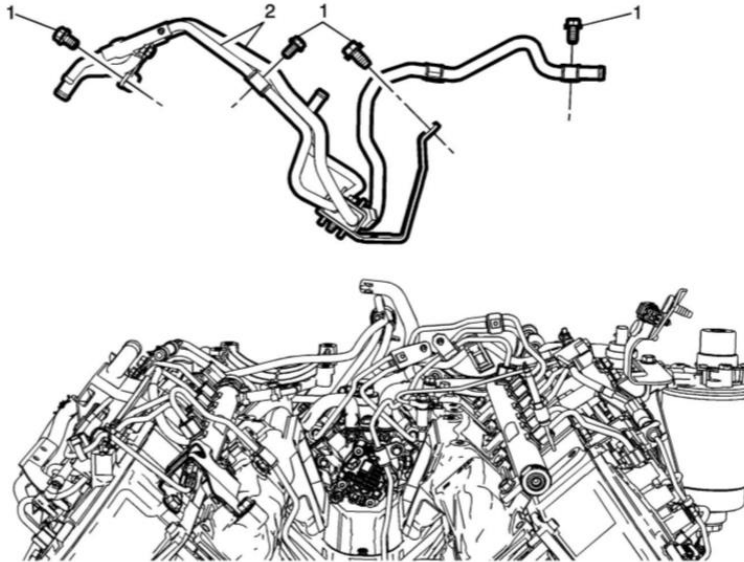

Fig. 9: Remove the rail-to-rail and CP4 lines

12. Disconnect electrical harness connectors for the fuel injection pump temperature sensor and pressure regulator.
13. Remove the four bolts that secure the CP4 injection pump to the cylinder block.

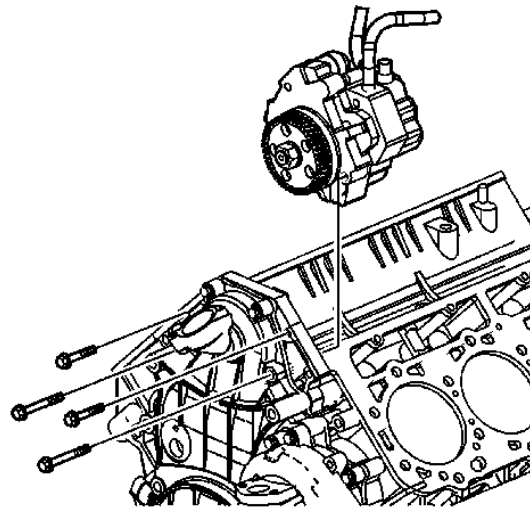

Fig. 10: Remove the CP4 pump

14. Remove CP4 injection pump.

INSTALLATION INSTRUCTIONS

PREPARE CP3 INJECTION PUMP FOR INSTALLATION

1. Remove the green fuel temperature sensor from the OLD injection pump and reconnect it to the proper engine wiring harness connector. Install the sensor into the provided fuel sensor block. It will be mounted near the AC compressor during final assembly later.
2. Hold the OLD injection pump by the drive gear in a vice with soft jaws.
3. Remove nut and gear from shaft.
4. Clean all mating surfaces.
5. Install the CP3 to engine block adapter to the new injection pump with the 3 bolts supplied in the kit. Be sure to lubricate the flange O-ring with engine oil prior to installation or an oil leak could occur. Torque the bolts to 20 ft-lb.
6. Install the gear and torque the gear nut to 75 ft-lb. DO NOT OVERTORQUE.
7. Remove the original Bosch CP3 feed and return fittings from the pump and install the new high flow CP3 feed and return fittings onto the CP3 pump. See Fig. 11.

IMPORTANT NOTE: The CP4 nut is longer than the CP3 nut, however, it will not interfere with the front cover. It will also provide the same amount of thread engagement. The shaft of the CP3 will be below the nut surface – THIS IS OK, SEE Fig. 12

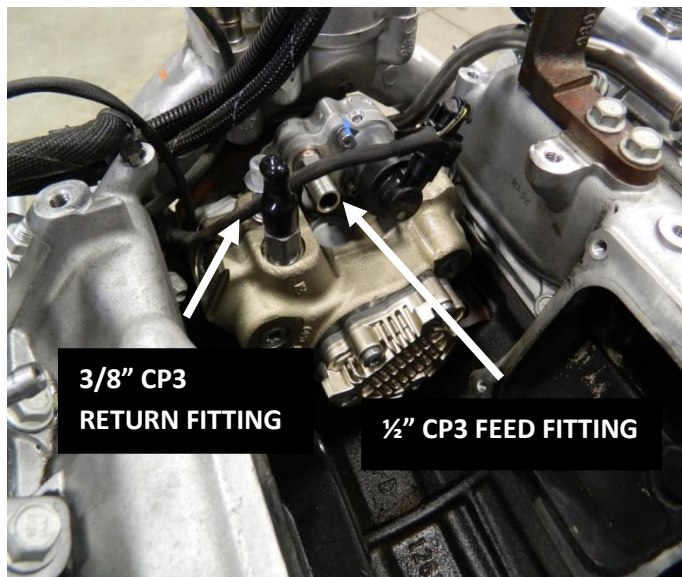

Fig. 11: Install the CP3 feed and return fittings



Fig. 12: Install the CP4 nut onto the CP3

INSTALLATION INSTRUCTIONS

INSTALLATION OF NEW CP3 PUMP

IMPORTANT NOTE: We recommend removing and inspecting the high-pressure regulator and inspecting it for debris. If debris is found in the high-pressure regulator, we recommend replacing the regulator, the injector return line and check valve assembly.

GM Pressure Regulator P/N: 12611872

GM Injector Return System P/N: 12639000

1. Lubricate the O-rings on the new injection pump adapter with engine oil and install onto the cylinder block. Note the CP3 pump does not need to be timed to the camshaft. Torque the four bolts to 18 ft-lb. Do not draw the pump into the block using the attachment bolts or they may strip out of the aluminum mounting plate, it must be pushed into position.

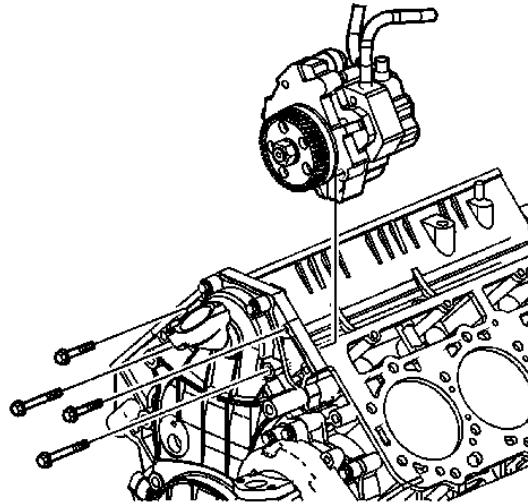

Fig. 13: Install the CP4

INSTALLATION INSTRUCTIONS

Before re-installing the rail-to-rail cross-over high-pressure fuel line, remove the high-pressure line clamp/bracket. This is most easily performed with the bracket held in a vice and separated with a small pry or heel bar. Do not nick or damage the high-pressure line in any way. Install cross-over high-pressure line and secondary high-pressure rail plug and torque fittings to 30 Nm (22 ft-lb). The high-pressure rail plug provided goes towards the open feed port toward rear of vehicle while the NEW supplied high-pressure feed line from the CP3 goes toward the front.

IMPORTANT NOTE: Torque is critical. Under or over torque will result in fuel leaks.

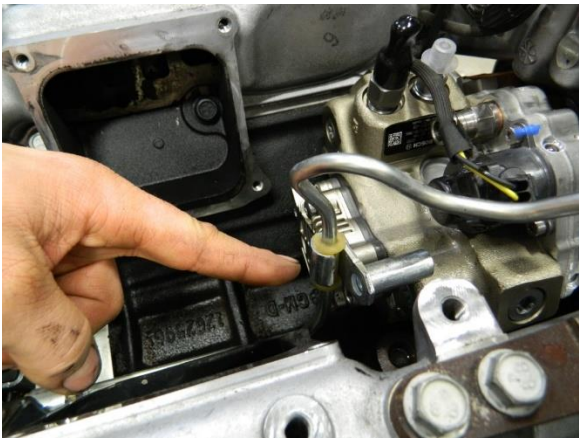

Fig. 14: Carefully remove high pressure line bracket

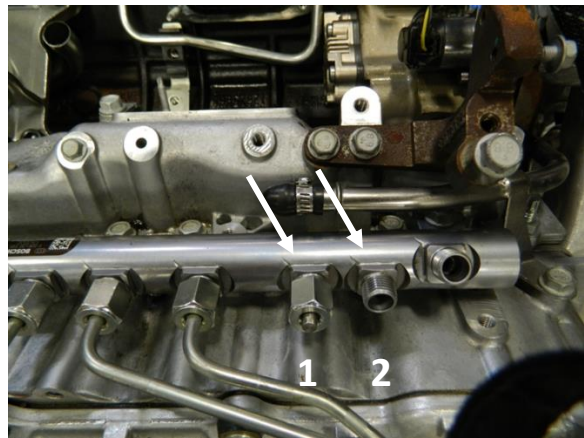

Fig. 15: Fuel rail nut (1) and high-pressure line (2)

2. Replace low pressure fuel supply line with new extension and install to engine. Torque the compression fitting to 35 Nm (26 ft-lb).

IMPORTANT NOTE: Clean and lightly lubricate low pressure feed tube compression fitting to ease installation in the valley.

3. Attach supplied fuel hose to the OEM fuel pump supply pipe and secure with constant tension clamps. Install the new fuel return hose. Be sure the return hose does not make contact with the high-pressure fuel line.
4. Install new high-pressure line from pump outlet to RH rail. Torque pump connection fittings to 38 Nm (28 ft-lb) and rail connection fitting to 30 Nm (22 ft-lb).

INSTALLATION INSTRUCTIONS

5. Remove the OE dosing injector fuel line assembly. Disconnect the fuel line from the dosing injector using a 3/16" fuel line disconnect tool (Dorman 904-484 or CTA 3477). Install the new dosing injector fuel supply line included with the kit. The line will be installed between the dosing injector and the fuel return line connection. Route the line away from the EGR cooler as shown in Fig. 16 below. **Do not route the line underneath the EGR cooler as shown in Fig. 17.**

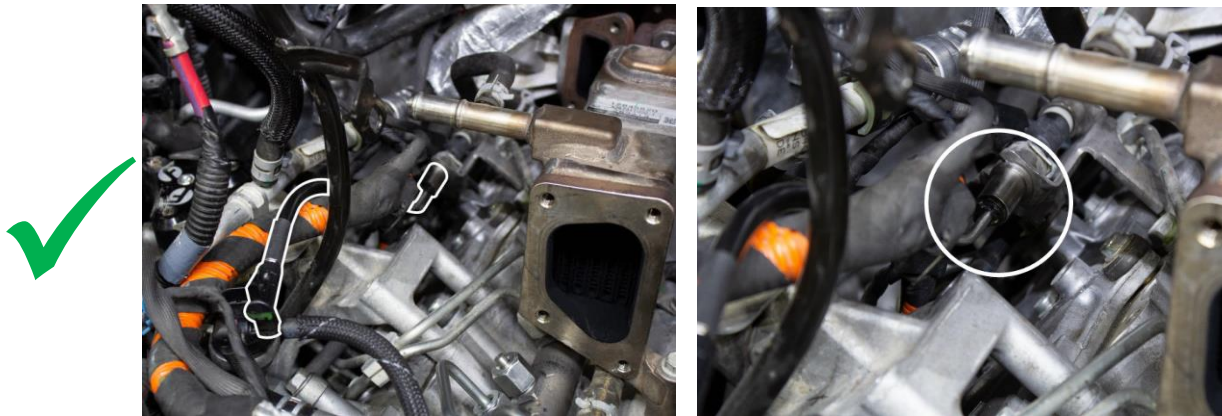

Fig. 16: CORRECT ROUTING: Connect the dosing injector to the return fuel line port with the new fuel line – Route the fuel line away from the EGR cooler and EGR manifold

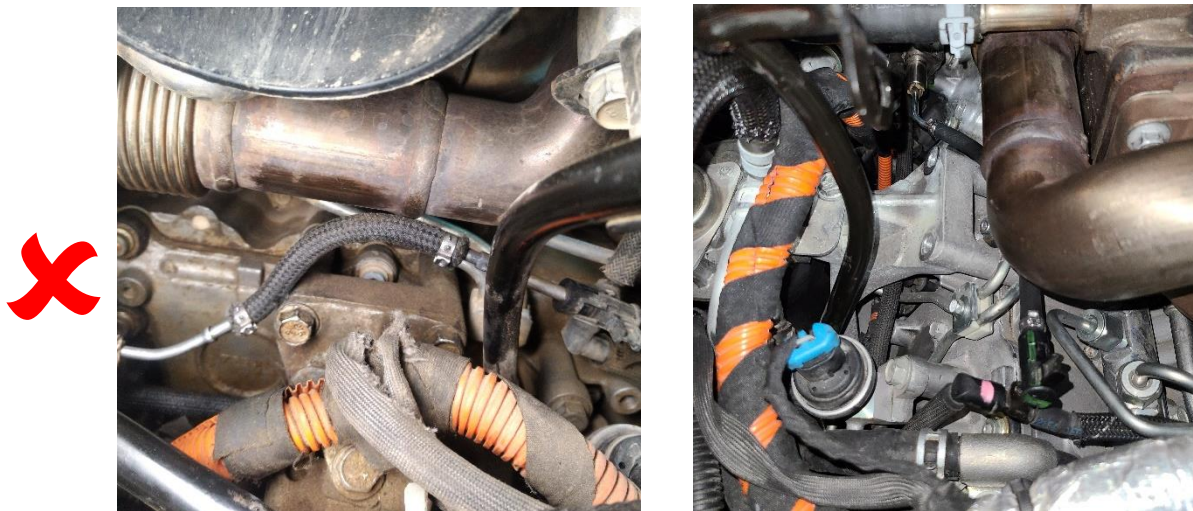

Fig. 17: INCORRECT ROUTING: DO NOT ROUTE THE DOSING INJECTOR FEED LINE UNDERNEATH OR NEAR THE EGR COOLER OR EGR MANIFOLD

6. Reinstall turbo coolant banjo pipe. Torque to 35 Nm (26 ft-lb).
7. Install center manifold (Y-bridge). Torque bolts and nuts to 10 Nm (89 in-lb).
8. Install turbocharger air inlet adapter. Torque clamp to 10 Nm (89 in-lb).
9. Install EGR cooler. TIP: hand-start all EGR fasteners prior to tightening. Torque bolts to 25 Nm (18 ft-lb).

INSTALLATION INSTRUCTIONS

10. Install EGR bypass pipe and EGR valve. Torque all EGR bolts to 25 Nm (18 ft-lb).
11. Install intake manifold tube to engine. Torque all fasteners to 25 Nm (18 ft-lb).
12. Reinstall alternator(s) Torque generator bolts to 58 Nm (43 ft-lb). Battery cable nut should be torqued to 12 Nm (106 in-lb).

13. Reinstall A/C compressor. Torque bolts to 58 Nm (43 ft-lb). When re-installing the A/C compressor, install the fuel temperature sensor block under the left side AC bolt.



Fig. 18: Fuel temperature sensor block location

14. Install drive belt and center intake manifold cover.
15. Reinstall cooling fan / pulley assembly. Torque to 41 Nm (30 ft-lb).
16. Reinstall fan shroud assembly. Torque fan shroud bolts to 8 Nm (71 in-lb).
17. Reconnect cold side charge air cooler duct and hot side charge air cooler pipe.
18. Reconnect air cleaner.
19. Reconnect chassis fuel line connections.
20. Reconnect battery cables. Torque to 5 Nm (44 in-lb).
21. Refill coolant using vacuum fill system or GM static fill procedure. Be sure to fill slowly so that overflow side of tank is at least ½ full.
22. Replace fuel filter cartridge. NEW GM AC DELCO P/N 12664429 is recommended to ensure reliability of the fuel system.
23. Affix the CARB EO decal included with the kit in a clearly visible location in the engine bay.
24. Prime fuel system:
 - a. Pump the priming pump repeatedly until it becomes hard.

INSTALLATION INSTRUCTIONS

- b. Loosen the bleeder screw until fuel flows freely with no air present.
- c. Check the fuel system for leaks.
- d. Crank the engine for 10 secs or until the engine fires.
- e. If the engine does not start and no leaks are observed, pump the priming pump repeatedly until it becomes hard again. Crank engine again for 10 second intervals until the engine starts. It may take 3-4 priming events to get the engine started.